

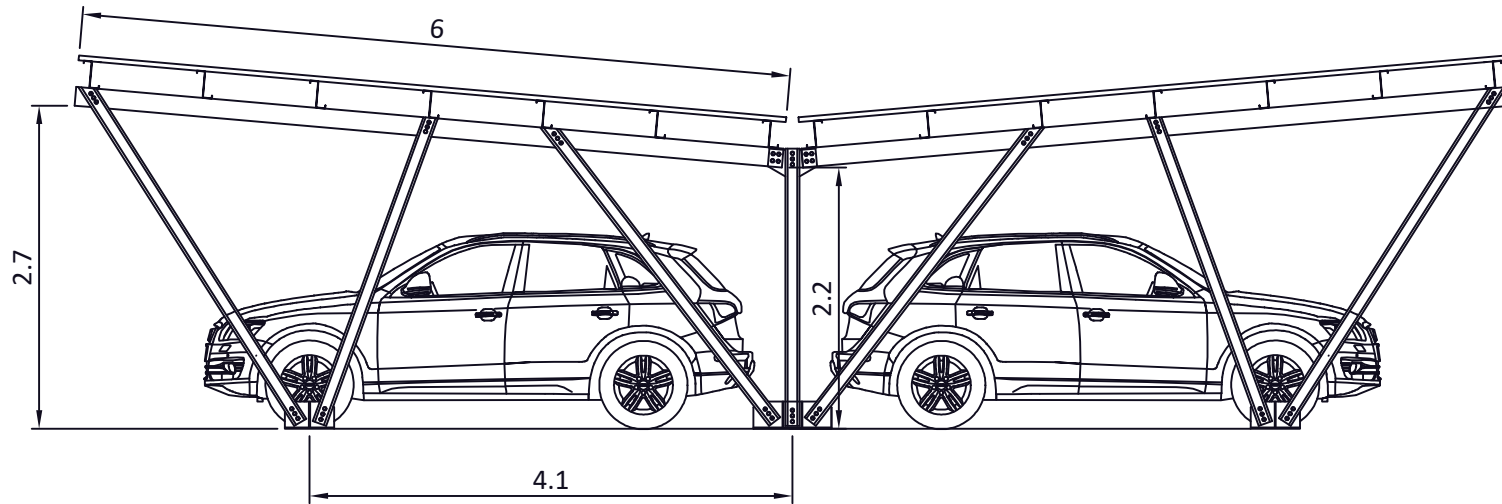

ATREYDES ENGINEERING



SPECIFICATIONS

Parking place effective size: 2.50x5.90 m
 Panel layout: horizontal (landscape mode)
 Canopy inclination: 5°
 Minimum free height: 2.2 m

MAXIMUM ADMISSIBLE LOADS:

Valid for the whole Spanish national territory according to Technical Building Code (CTE) and European territory according to Eurocode, subject to:

Wind:

Average wind speed: 29m/s [104km/h]*.
 Gust speed wind: 33.5m/s [121km/h].

Snow:

Snow load: 0.6kN/m2**.

Earthquake:

Calculations according to Seismic Resistant Construction Standard NCSE-02.
 Base Acceleration: 0.23 m/s2*
 Terrain: type II
 Ductility: low
 Damping: 5%

* Valid for the entire Spanish national territory

**Consult the installation in the communities of Castilla-León, Castilla-La Mancha, Aragón and Navarra where this load is exceeded by regulations.

MATERIALS AND FINISHINGS:

Pillars, beams, purlins and foundation anchors: hot-dip galvanized S235 steel ISO 1461.
 Fixings for panels: Aluminum 6005A T6.
 Fasteners: steel grade 8.8 zinc-plated.
 Sheet metal: red lacquered S235 steel for the upper part and white for the lower one.

ASSEMBLY:

The structure allows the weight of two operators maximum on the corrugated sheet for the installation of the modules, as long as they step on the steel sheet valleys under purlins, so as not to dent the plates.

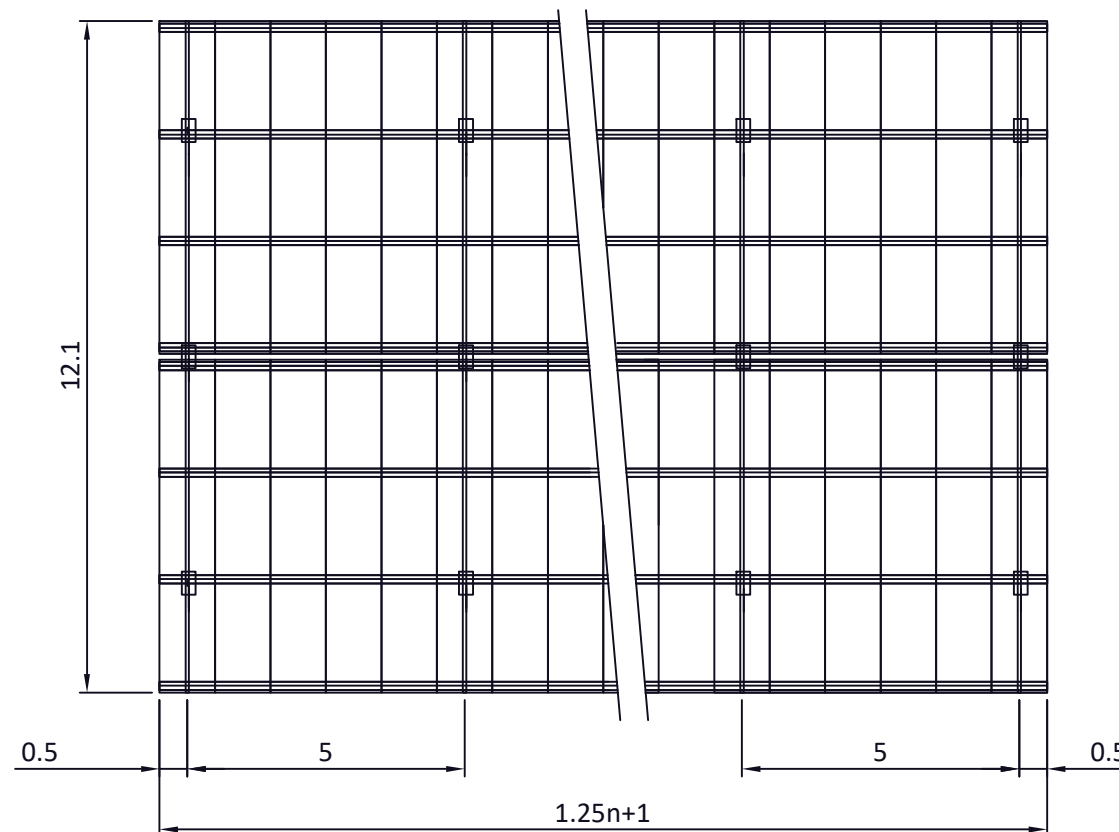

Parking place dimensions

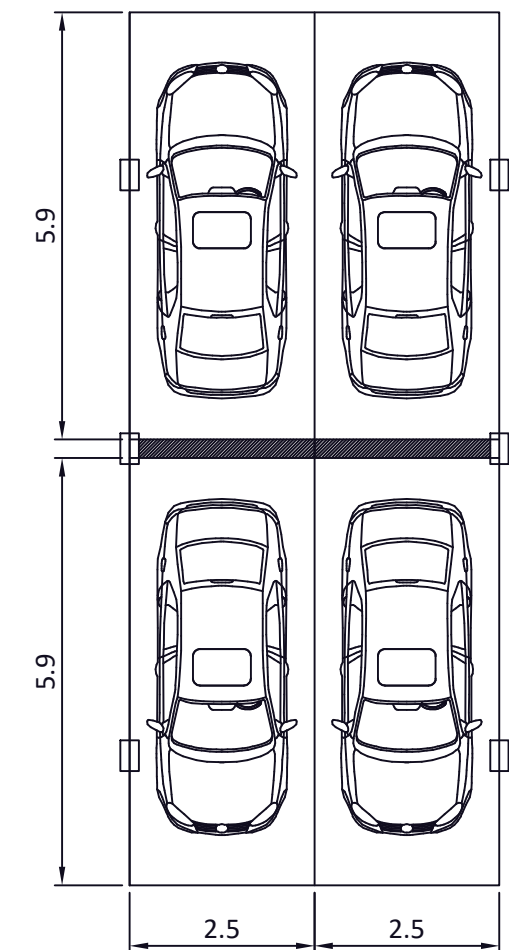

ESTIMATE YOUR PROJECT

COSTS:

Components	Uns.	Price/Uns. [€]**
Parking places*	n	
Gantries	0.25n+1	1500
Purlins	2n	165
Sheet metals	2.5n+2	65
Delivery	1	350

(*) Multiple of 4

DELIVERY TIME: 4-5 weeks*

(**) Prices are shown exclusive of VAT and are indicative.
 Prices and delivery times will depend on the project specifications as well as the final location and dimensions of the photovoltaic panel to be installed.



FOUNDATION FOOTINGS

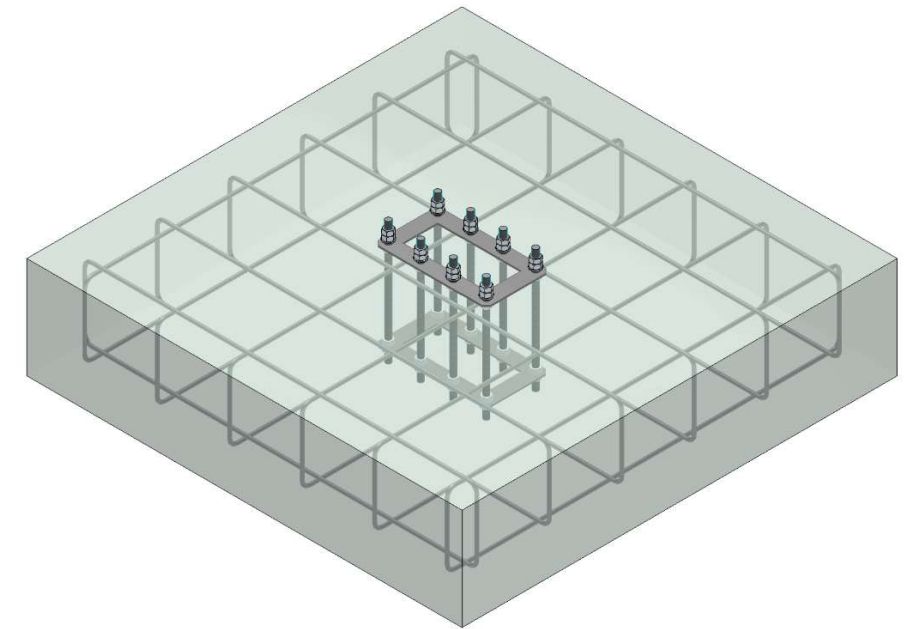
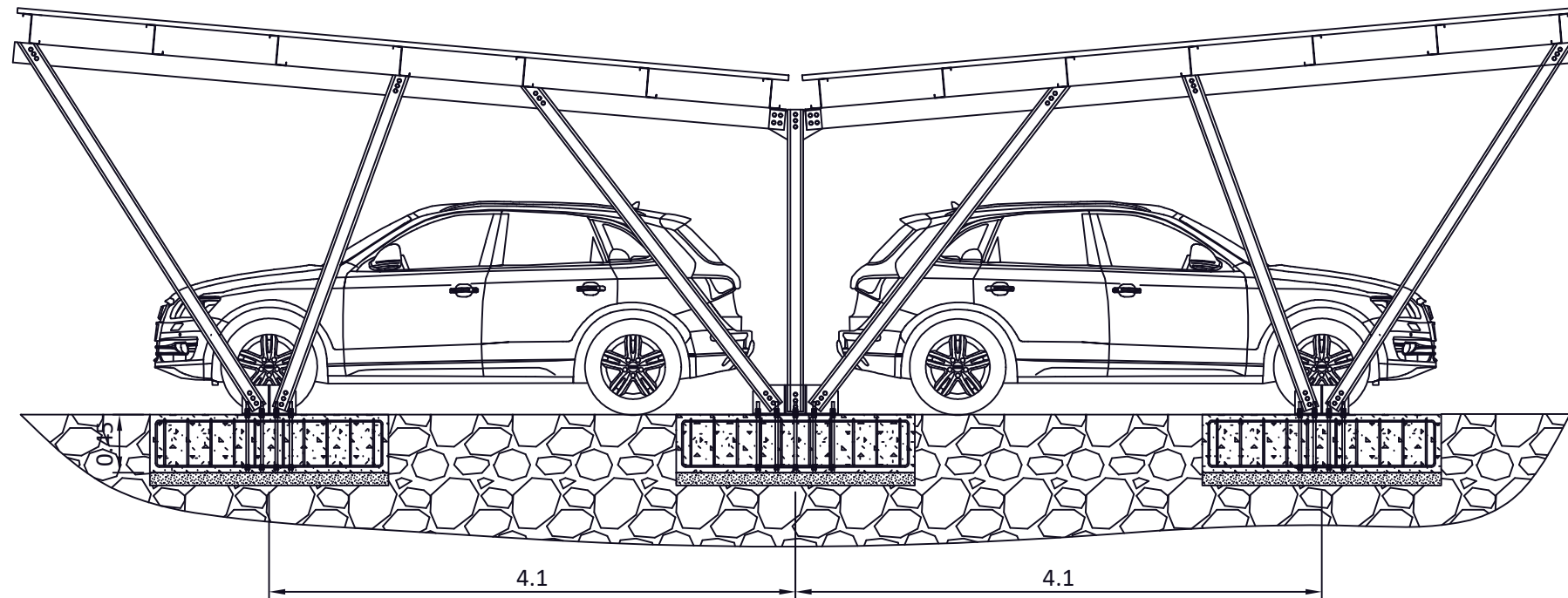

REACTIONS	
Rx [kN]	±3.18
Ry [kN]	±4.51
Rz [kN]	±39.51
Mx [kNm]	±0.36
My [kNm]	±0.62
Mz [kNm]	±0.48

SPECIFICATIONS

All foundations need a Geotechnical Study to identify the resistant layer and to rule out structurally problematic soils (expansive clays, etc...). However, Atreydes Engineering proposes a solution by means of isolated footings for generic terrains, which will have to be verified with the Geotechnical Study of the installation site. Having said this, the design of the footings is defined:

DIMENSIONS:

Footing: 185x185x45 cm.
Reinforcement: 10Ø12c/18

CALCULATION REQUIREMENTS:

Footings defined in accordance with Technical Building Code (CTE) together with Structural Code (CE) for maximum allowable loads and subject to:

- Allowable soil stresses:
- Persistent situations: 0.2MPa
 - Seismic and accidental situations: 0.3MPa.

MATERIALS:

Concrete: HA-25, Yc = 1.5, maximum aggregate size: 30mm
Reinforcement: B500S, Ys = 1.15

VERIFICATIONS:

- Tensions on the ground
- Overturning of the footing
- Footing deflection
- Shear of footing
- Oblique compression in the footing
- Minimum depth
- Minimum geometric size
- Minimum diameter of reinforcement bars
- Maximum spacing between reinforcing bars
- Minimum spacing between reinforcing bars

SCOPE AND SUPPLY

Atreydes Engineering does not supply the concrete or the reinforcement of the defined footings. We understand that it must be a collaborative work with the Geotechnical Study.

The connection anchors are supplied with the geometry of the coupling between the footing and the pillars, the necessary planimetry of the position of these anchors so that the carport can be assembled on them and the load envelope on the footings, in the case that the defined design is not validated by the Geotechnical Study.

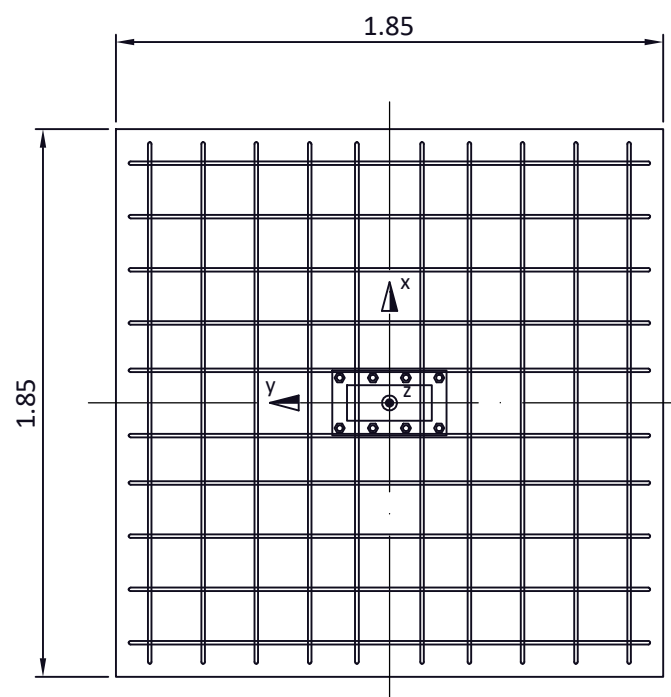

Connection anchors

